

FEATURES

- Planar die construction.
- 500mW power dissipation.
- General purpose, medium current.
- Ideally suited for automated assembly processes.

SOD-123

APPLICATIONS

- Zener diode.
- Ultra-small surface mount package.



MAXIMUM RATING @ Ta=25°C unless otherwise specified

Characteristic	Symbol	Value	Unit
Forward Voltage @ I _F =10mA	V _F	0.9	V
Power Dissipation	P _d	500	mW
Thermal resistance, junction to ambient air	R _{θJA}	350	°C/W
Junction temperature	T _j	150	°C
Storage temperature range	T _{stg}	-65-150	°C

Notes: 1. Device mounted on ceramic PCB; 7.6 mm x 9.4 mm x 0.87 mm with pad areas 25 mm².

2. Tested with pulses, T_p ≤ 1.0ms.

ELECTRICAL CHARACTERISTICS @ Ta=25°C unless otherwise specified

Type Number	Type Code	Zener Voltage Range			Test Current	Maximum Zener Impedance		Maximum Reverse Leakage Current	
		V _Z @I _{ZT}				I _{ZT}	Z _{ZT} @I _{ZT}	Z _{ZK} @I _{ZK} =0.25mA	I _R
		Nom(V)	Min(V)	Max(V)	mA	Ω		μA	V
MMSZ5221B	C1	2.4	2.28	2.52	20	30	1200	100	1.0
MMSZ5223B	C3	2.7	2.57	2.84	20	30	1300	75	1.0
MMSZ5225B	C5	3.0	2.85	3.15	20	30	1600	50	1.0
MMSZ5226B	G1	3.3	3.14	3.47	20	28	1600	25	1.0
MMSZ5227B	G2	3.6	3.42	3.78	20	24	1700	15	1.0
MMSZ5228B	G3	3.9	3.71	4.10	20	23	1900	10	1.0
MMSZ5229B	G4	4.3	4.09	4.52	20	22	2000	5.0	1.0
MMSZ5230B	G5	4.7	4.47	4.94	20	19	1900	5.0	2.0
MMSZ5231B	E1	5.1	4.85	5.36	20	17	1600	5.0	2.0
MMSZ5232B	E2	5.6	5.32	5.88	20	11	1600	5.0	3.0
MMSZ5233B	E3	6.0	5.70	6.30	20	7	1600	5.0	3.5
MMSZ5234B	E4	6.2	5.89	6.51	20	7	1000	5.0	4.0
MMSZ5235B	E5	6.8	6.46	7.14	20	5	750	3.0	5.0
MMSZ5236B	F1	7.5	7.13	7.88	20	6	500	3.0	6.0
MMSZ5237B	F2	8.2	7.79	8.61	20	8	500	3.0	6.5
MMSZ5238B	F3	8.7	8.27	9.14	20	8	600	3.0	6.5
MMSZ5239B	F4	9.1	8.65	9.56	20	10	600	3.0	7.0
MMSZ5240B	F5	10	9.50	10.50	20	17	600	3.0	8.0
MMSZ5241B	H1	11	10.45	11.55	20	22	600	2.0	8.4
MMSZ5242B	H2	12	11.40	12.60	20	30	600	1.0	9.1
MMSZ5243B	H3	13	12.35	13.65	9.5	13	600	0.5	9.9
MMSZ5245B	H5	15	14.25	15.75	8.5	16	600	0.1	11
MMSZ5246B	J1	16	15.20	16.80	7.8	17	600	0.1	12
MMSZ5248B	J3	18	17.10	18.90	7.0	21	600	0.1	14
MMSZ5250B	J5	20	19.00	21.00	6.2	25	600	0.1	15
MMSZ5251B	K1	22	20.90	23.10	5.6	29	600	0.1	17
MMSZ5252B	K2	24	22.80	25.20	5.2	33	600	0.1	18
MMSZ5254B	K4	27	25.65	28.35	5.0	41	600	0.1	21
MMSZ5255B	K5	28	26.60	29.40	4.5	44	600	0.1	21
MMSZ5256B	M1	30	28.50	31.5	4.2	49	600	0.1	23
MMSZ5257B	M2	33	31.35	34.65	3.8	58	700	0.1	25
MMSZ5258B	M3	36	34.20	37.80	3.4	70	700	0.1	27
MMSZ5259B	M4	39	37.05	40.95	3.2	80	800	0.1	30
MMSZ5260B	M5	43	40.85	45.15	3.0	93	900	0.1	33

TYPICAL CHARACTERISTICS @ $T_a=25^\circ\text{C}$ unless otherwise specified

Fig. 1 Power Dissipation vs Ambient Temperature

PACKAGE OUTLINE

Plastic surface mounted package

SOD-123

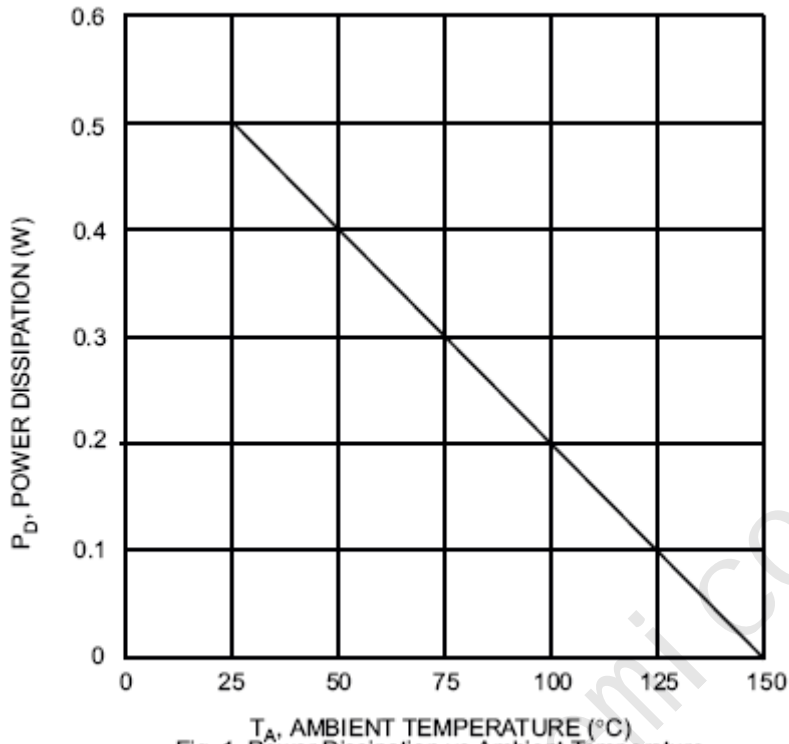
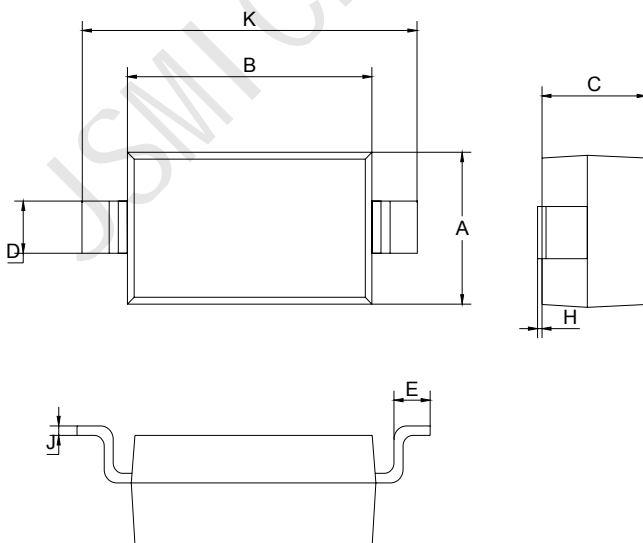

SOD-123		
Dim	Min	Max
A	1.4	1.8
B	2.55	2.85
C	1.15 Typical	
D	0.5	0.6
E	0.3	0.4
H	0.02	0.10
J	0.1 Typical	
K	3.55	3.85
All Dimensions in mm		

SOLDERING FOOTPRINT

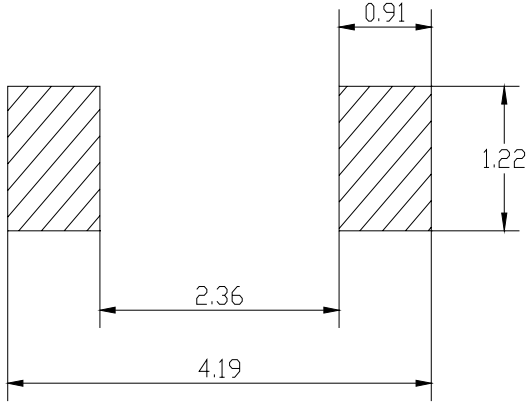

Unit : mm

PACKAGE INFORMATION

Device	Package	Shipping
MMSZ5221B-MMSZ5260B	SOD-123	3000/Tape&Reel