

Feature

-20V/-3A, $R_{DS(ON)} = 100m\Omega(MAX)$ @ $V_{GS} = -4.5V$.

$R_{DS(ON)} = 120m\Omega(MAX)$ @ $V_{GS} = -2.5V$.

Super High dense cell design for extremely low $R_{DS(ON)}$

Reliable and Rugged

SOT-23 for Surface Mount Package

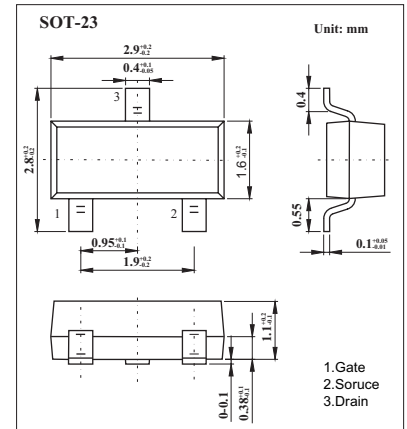
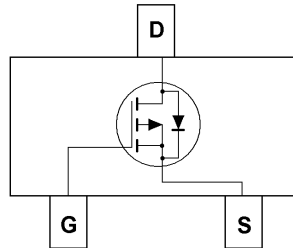

SOT-23

Applications

- Power Management
- Portable Equipment and Battery Powered Systems.

Absolute Maximum Ratings $T_A=25^\circ C$ Unless Otherwise noted

Parameter	Symbol	Rating	Unit	
Drain-Source Voltage	V_{DS}	-20	V	
Gate-Source Voltage	V_{GS}	± 8		
Continuous Drain Current	I_D	$T_a=25^\circ C$	-3	A
		$T_a=70^\circ C$	-2	
Pulsed Drain Current	I_{DM}	-10		
Power Dissipation	P_D	$T_a=25^\circ C$	1.5	W
		$T_a=70^\circ C$	1.25	
Thermal Resistance.Junction- to-Ambient *1	R_{thJA}		100	$^\circ C/W$
Thermal Resistance.Junction- to-Ambient *3		166		
Junction Temperature	T_J	150	$^\circ C$	
Storage Temperature Range	T_{stg}	-55 to 150		

Electrical Characteristics $T_A=25^\circ C$ Unless Otherwise noted

Parameter	Symbol	Test Conditions	Min	Typ	Max	Unit
Drain-Source Breakdown Voltage	V_{DSS}	$I_D=-250 \mu A, V_{GS}=0V$	-20			V
Zero Gate Voltage Drain Current	I_{DSS}	$V_{DS}=-20V, V_{GS}=0V$			-1	μA
		$V_{DS}=-20V, V_{GS}=0V, T_J=55^\circ C$			-10	
Gate-Body leakage current	I_{GSS}	$V_{DS}=0V, V_{GS}=\pm 8V$			± 100	nA
Gate Threshold Voltage	$V_{GS(th)}$	$V_{DS}=V_{GS}, I_D=-250 \mu A$	-0.45		-1	V
Static Drain-Source On-Resistance	$R_{DS(on)}$	$V_{GS}=-4.5V, I_D=-2.8A$		105	110	m Ω
		$V_{GS}=-2.5V, I_D=-2.0A$		115	120	
On state drain current	$I_{D(ON)}$	$V_{GS}=-4.5V, V_{DS}\leq -5V$	-6			A
		$V_{GS}=-2.5V, V_{DS}\leq -5V$	-3			
Forward Transconductance	g_{FS}	$V_{DS}=-5V, I_D=-2.8A$		6.5		S

Marking

Marking	YDs **
---------	--------

Typical Characteristics

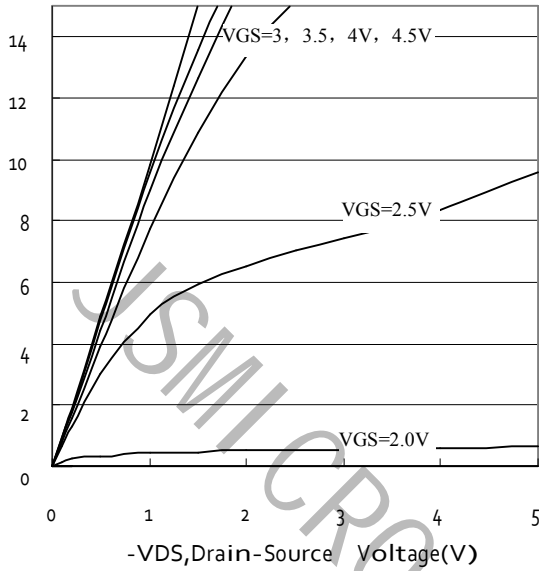

Figure 1. Output Characteristics

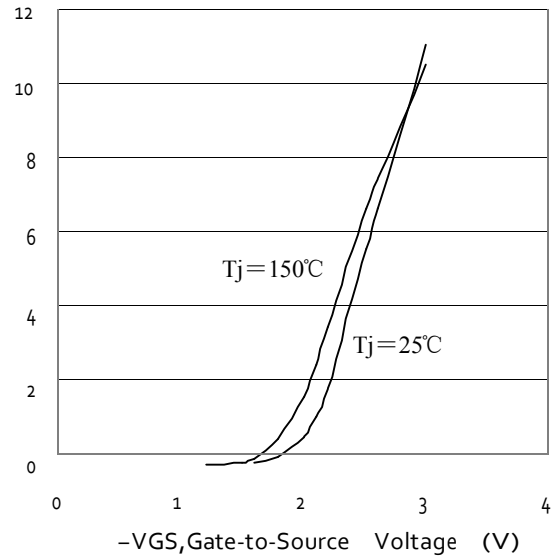

Figure 2. Transfer Characteristics

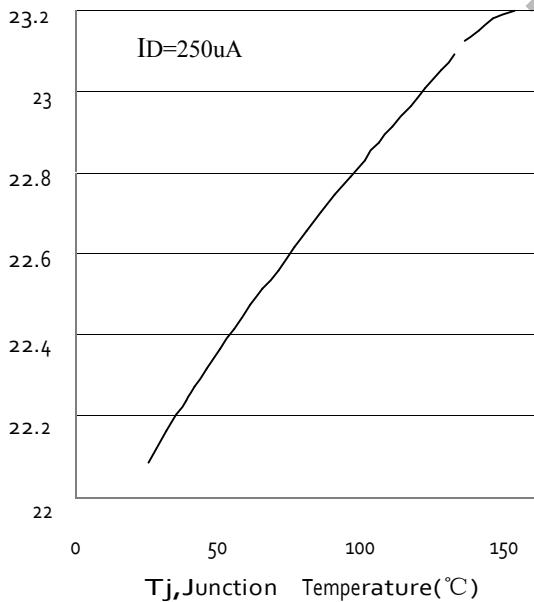

Figure 3. Breakdown Voltage Variation with Temperature

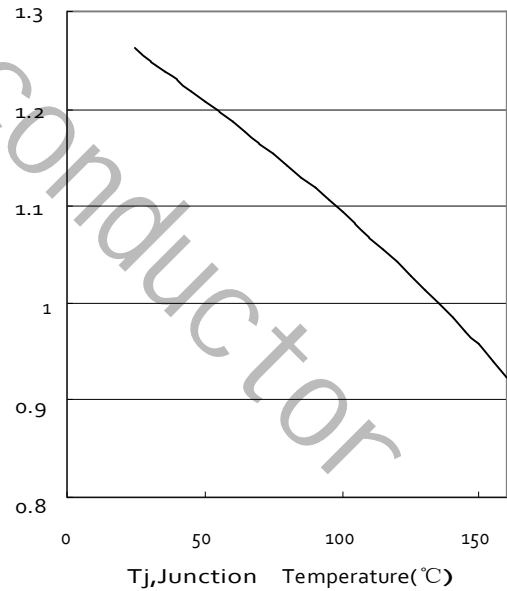

Figure 4. Gate Threshold Variation with Temperature

Typical Characteristics

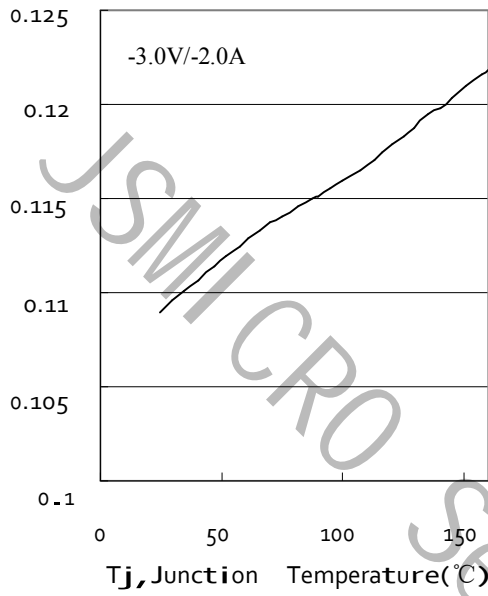

Figure 5. On-Resistance Variation with Temperature

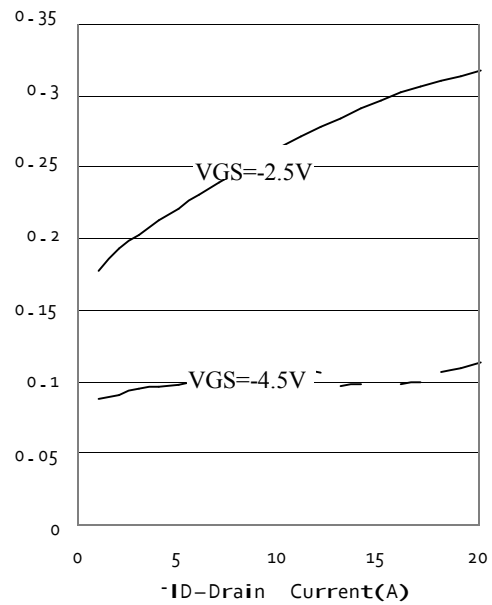

Figure 6. On-Resistance vs. Drain Current

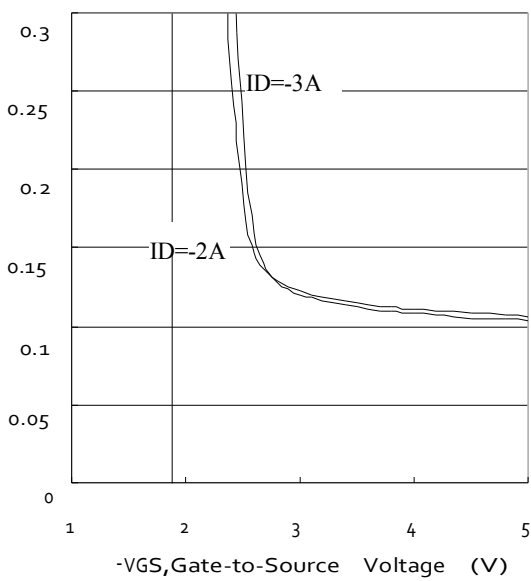

Figure 7. On-Resistance vs. Gate-to-Source Voltage

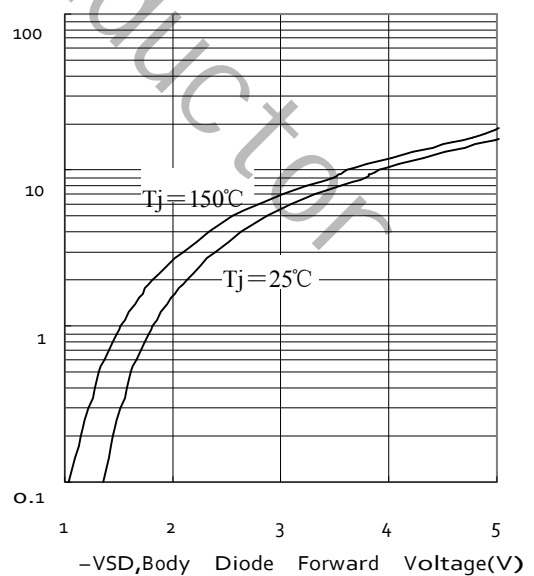
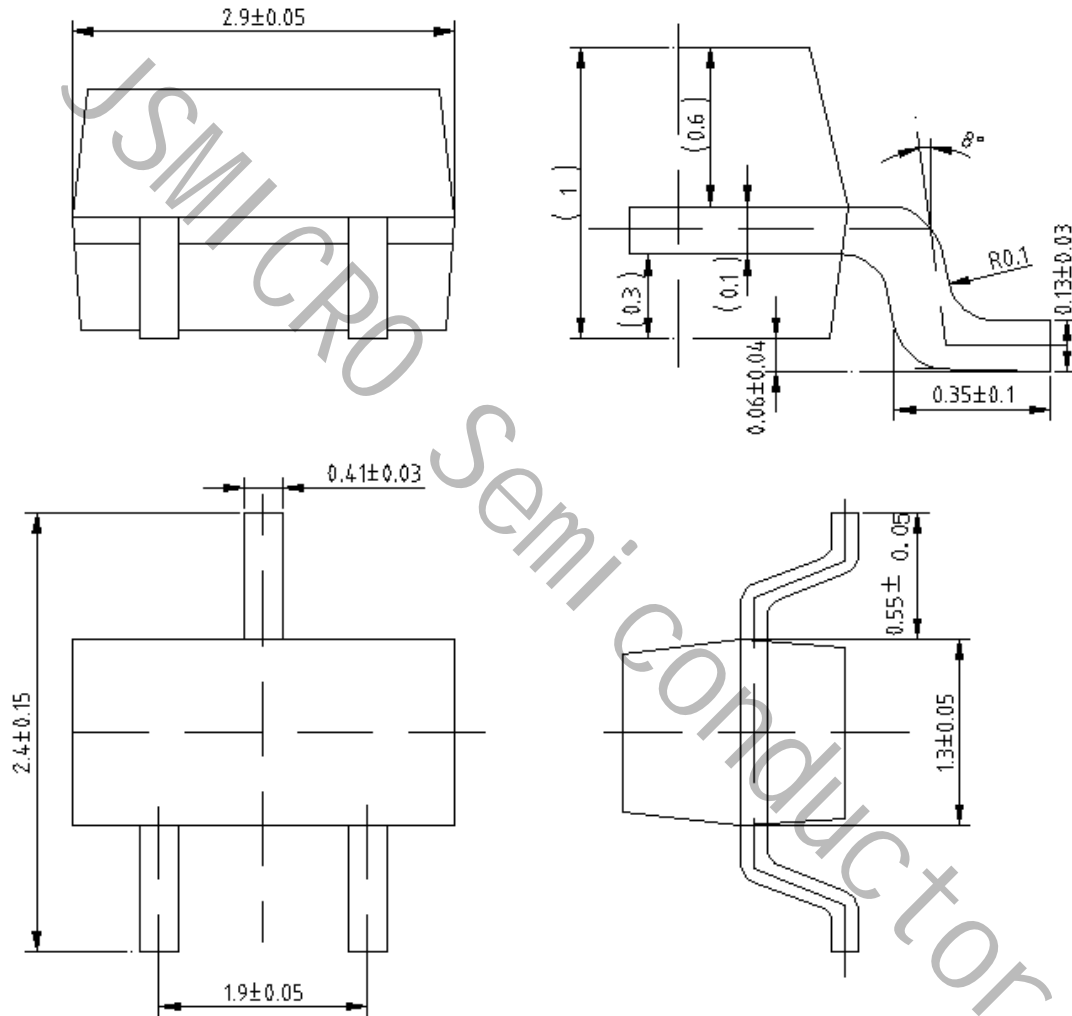

Figure 8. Source-Drain Diode Forward Voltage

Package Outline Dimensions (UNIT: mm)

SOT-23



SOT-23 Carrier Tape

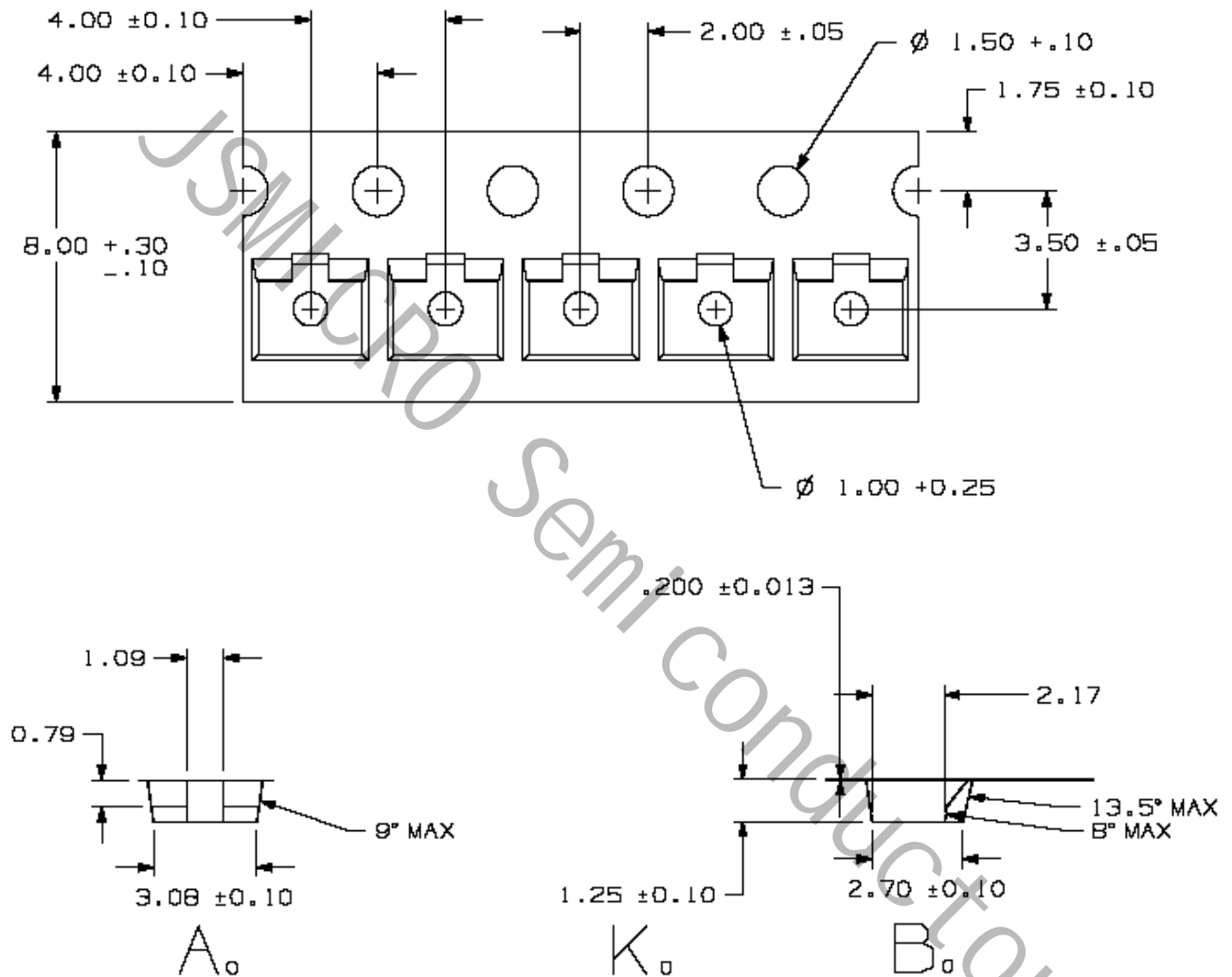

SOT-23 Carrier Reel

