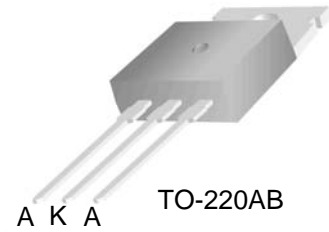


● **Features:**

- Common Cathode Structure
- Low Power Loss and High Efficiency
- Low Forward Voltage Drop
- High Surge Capability

● **Application:**

- High Frequency Switch
- Free Wheeling, and Polarity Protection Applications



**Absolute Maximum Ratings**( $T_c=25^{\circ}\text{C}$  unless otherwise noted)

| Symbol      | Parameter  | Value                         | Unit               |
|-------------|--|-------------------------------|--------------------|
| $V_{RRM}$   | Maximum Repetitive Reverse Voltage                           | 100                           | V                  |
| $V_R$       | Maximum DC Reverse Voltage                                   | 100                           | V                  |
| $I_{F(AV)}$ | Average Rectified Forward Current, $T_c=120^{\circ}\text{C}$ | 10(Per Leg)<br>20(Per Device) | A                  |
| $I_{FSM}$   | Peak Forward Surge Current, 8.3ms Half Sine wave             | 150                           | A                  |
| $T_j$       | Operating Junction Temperature                               | 150                           | $^{\circ}\text{C}$ |
| $T_{stg}$   | Storage Temperature Range                                    | -55 to +150                   | $^{\circ}\text{C}$ |

**Thermal Characteristics**( $T_c=25^{\circ}\text{C}$  unless otherwise noted)

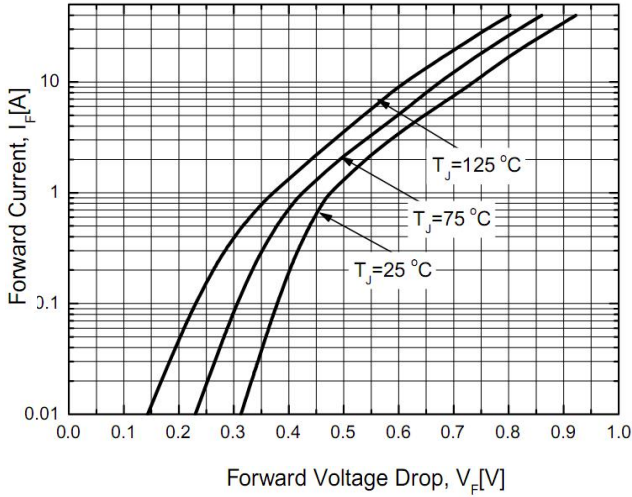
| Symbol          | Parameter                                       | Max | Unit                        |
|-----------------|---|-----|-----------------------------|
| $R_{\theta JC}$ | Thermal Resistance, Junction to Case Per Leg    | 2.2 | $^{\circ}\text{C}/\text{W}$ |
| $R_{\theta JA}$ | Thermal Resistance, Junction to Ambient Per Leg | 92  | $^{\circ}\text{C}/\text{W}$ |

**Electrical Characteristics**( $T_c=25^{\circ}\text{C}$  unless otherwise noted)

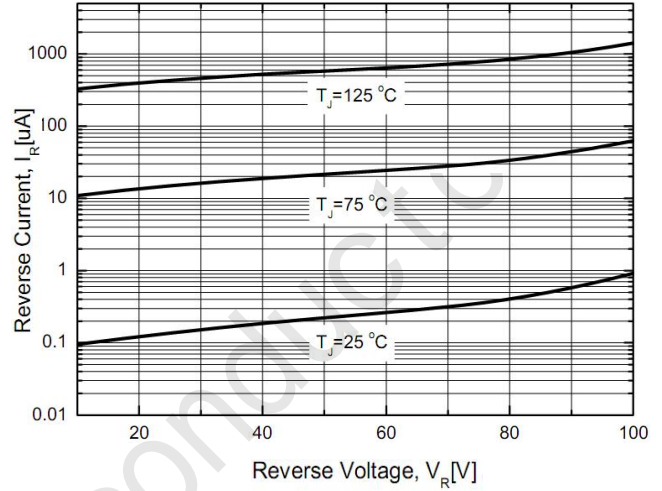
| Symbol    | Parameter                          | Test Conditions  | Min | Max                      | Unit |
|-----------|------------------------------------|--|-----|--------------------------|------|
| $V_{RRM}$ | Maximum Repetitive Reverse Voltage | $I_R=100\mu\text{A}$   | 100 |                          | V    |
| $I_R$     | Reverse Current                    | $V_R=100\text{V}$ $T_c=25^{\circ}\text{C}$<br>$V_R=100\text{V}$ $T_c=125^{\circ}\text{C}$  |     | 0.1<br>5                 | mA   |
| $V_F$     | Forward Voltage                    | $I_F=10\text{A}$ $T_c=25^{\circ}\text{C}$<br>$I_F=10\text{A}$ $T_c=125^{\circ}\text{C}$<br>$I_F=20\text{A}$ $T_c=25^{\circ}\text{C}$<br>$I_F=20\text{A}$ $T_c=125^{\circ}\text{C}$ |     | 0.9<br>0.8<br>1.0<br>0.9 | V    |

**Typical Performance Characteristics**

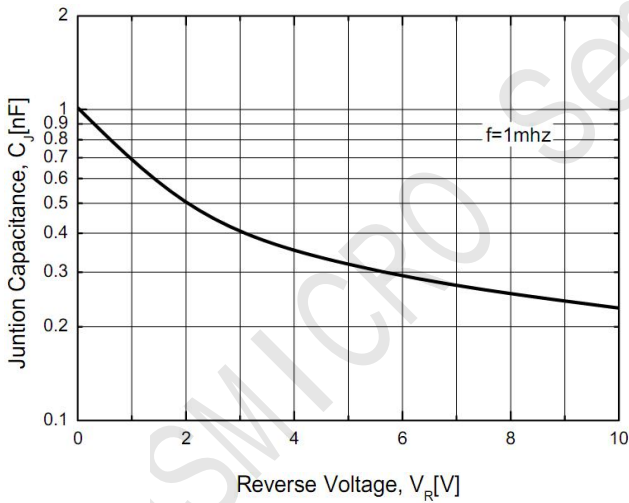
**Figure 1. Forward Current Characteristics**



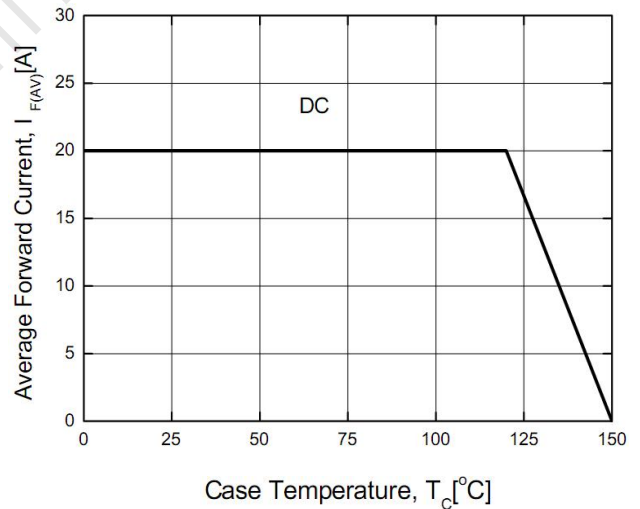
**Figure 2. Reverse Leakage Current**



**Figure 3. Junction Capacitance**

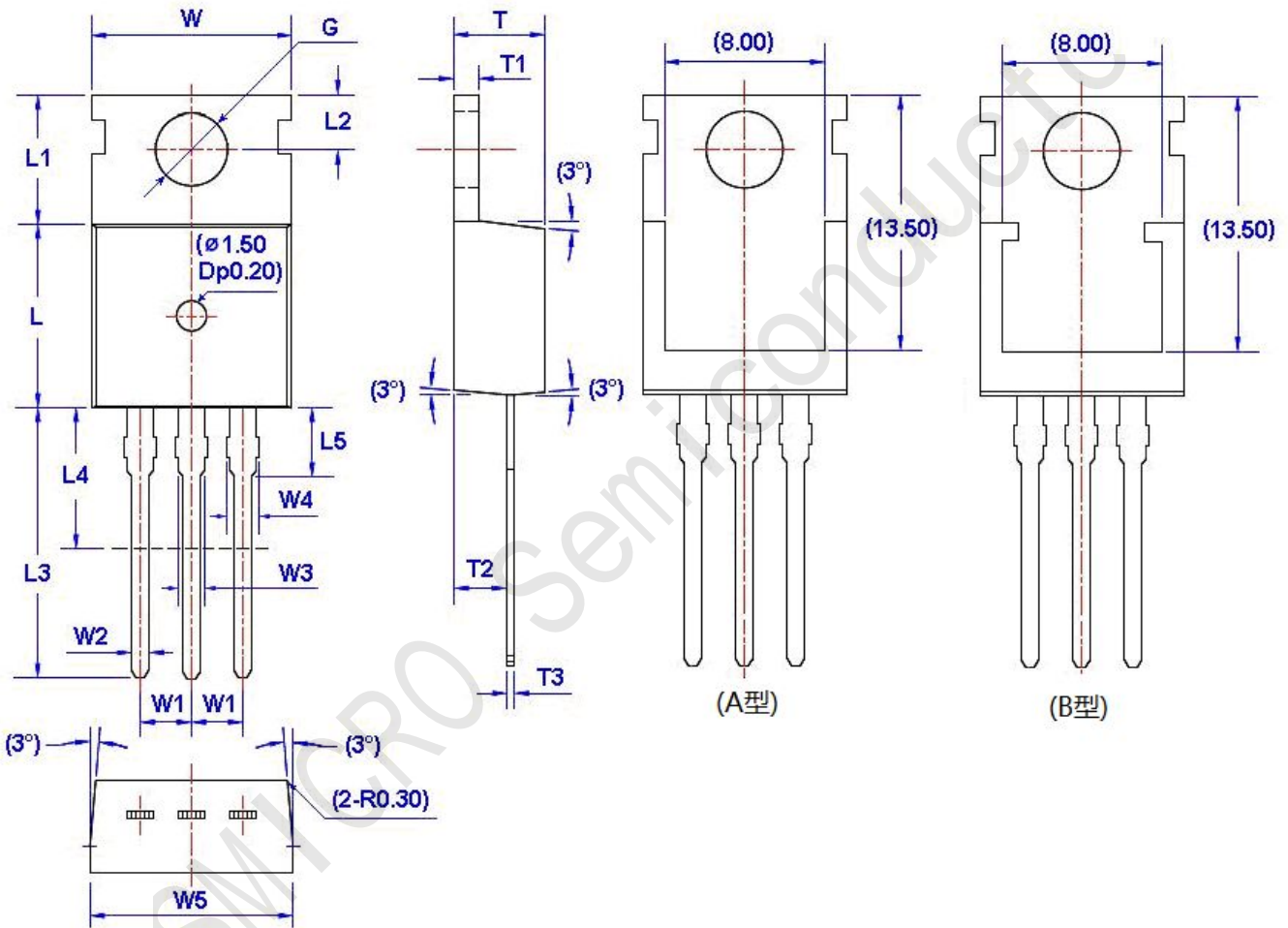


**Figure 4. Power Derating**



TO-220AB

Unit: mm



| Symbol | Size       |       | Symbol | Size  |       | Symbol | Size |      | Symbol | Size |      |
|--------|------------|-------|--------|-------|-------|--------|------|------|--------|------|------|
|        | Min        | Max   |        | Min   | Max   |        | Min  | Max  |        | Min  | Max  |
| W      | 9.66       | 10.28 | W5     | 9.80  | 10.20 | L4**   | 6.20 | 6.60 | T3     | 0.45 | 0.60 |
| W1     | 2.54 (TYP) |       | L      | 9.00  | 9.40  | L5     | 2.79 | 3.30 | G(Φ)   | 3.50 | 3.70 |
| W2     | 0.70       | 0.95  | L1     | 6.40  | 6.80  | T      | 4.30 | 4.70 |        |      |      |
| W3     | 1.17       | 1.37  | L2     | 2.70  | 2.90  | T1     | 1.15 | 1.40 |        |      |      |
| W4*    | 1.32       | 1.72  | L3     | 12.70 | 14.27 | T2     | 2.20 | 2.60 |        |      |      |