

● **Features:**

- Common Cathode Structure
- Low Power Loss and High Efficiency
- Low Forward Voltage Drop
- High Surge Capability

● **Application:**

- High Frequency Switch
- Free Wheeling, and Polarity Protection Applications

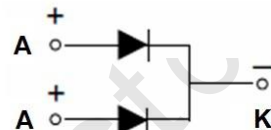
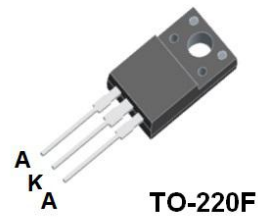

**Absolute Maximum Ratings**(Tc=25°C unless otherwise noted)

Symbol	Parameter	Value	Unit
V <sub>RRM</sub>	Maximum Repetitive Reverse Voltage	600	V
V <sub>R</sub>	Maximum DC Reverse Voltage	600	V
I <sub>F(AV)</sub>	Average Rectified Forward Current, Tc=120°C	5(Per Leg) 10(Per Device)	A
I <sub>FSM</sub>	Peak Forward Surge Current, 8.3ms Half Sine wave	100	A
T <sub>j</sub>	Operating Junction Temperature	150	°C
T <sub>stg</sub>	Storage Temperature Range	-55 to+150	°C

**Thermal Characteristics**(Tc=25°C unless otherwise noted)

Symbol	Parameter	Max	Unit
R <sub>θJC</sub>	Thermal Resistance, Junction to Case Per Leg	4.0	°C /W

**Electrical Characteristics**(Tc=25°C unless otherwise noted)

Symbol	Parameter	Test Conditons	Min	Max	Unit
V <sub>RRM</sub>	Maximum Repetitive Reverse Voltage	I <sub>R</sub> =100μA	600		V
I <sub>R</sub>	Reverse Current	V <sub>R</sub> =600V T <sub>C</sub> =25°C V <sub>R</sub> =600V T <sub>C</sub> =125°C		0.1 5	mA
V <sub>F</sub>	Forward Voltage	I <sub>F</sub> =5A T <sub>C</sub> =25°C I <sub>F</sub> =5A T <sub>C</sub> =125°C I <sub>F</sub> =10A T <sub>C</sub> =25°C I <sub>F</sub> =10A T <sub>C</sub> =125°C		1.40 1.30 1.50 1.40	V
T <sub>rr</sub>	Maximum Reverse Recovery Time	I <sub>F</sub> =0.5A I <sub>R</sub> =1.0A I <sub>rr</sub> =0.25A		50	ns

## Typical Performance Characteristics

Figure 1. Forward Current Characteristics

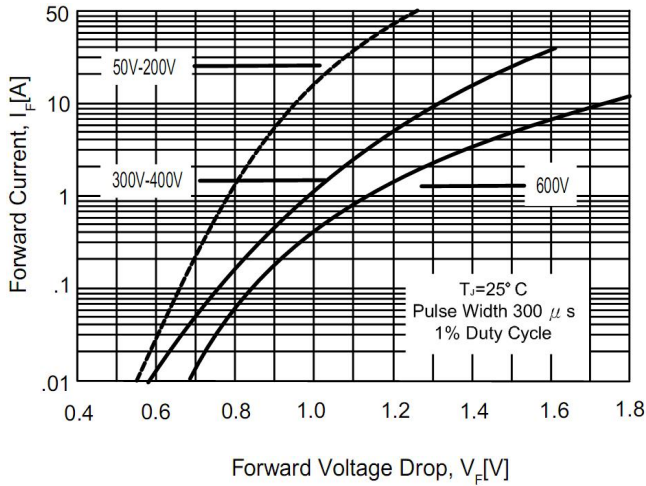

Figure 2. Reverse Leakage Current

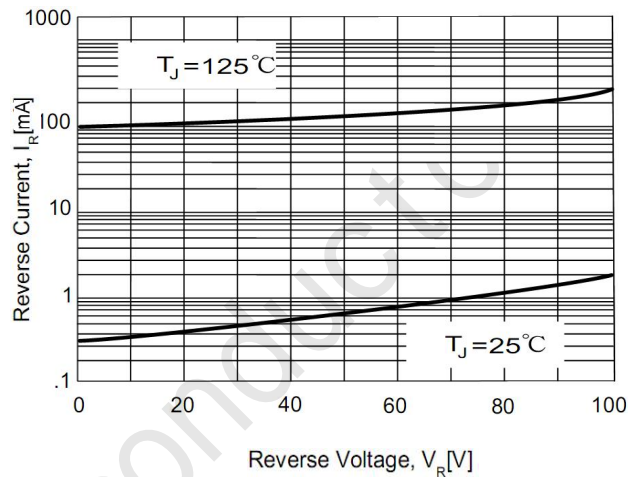

Figure 3. Junction Capacitance

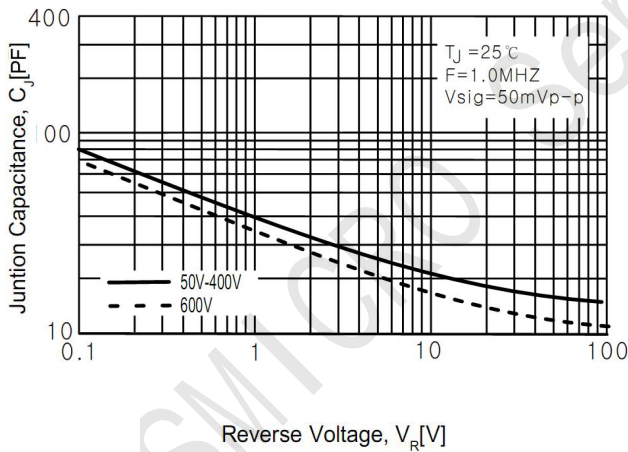
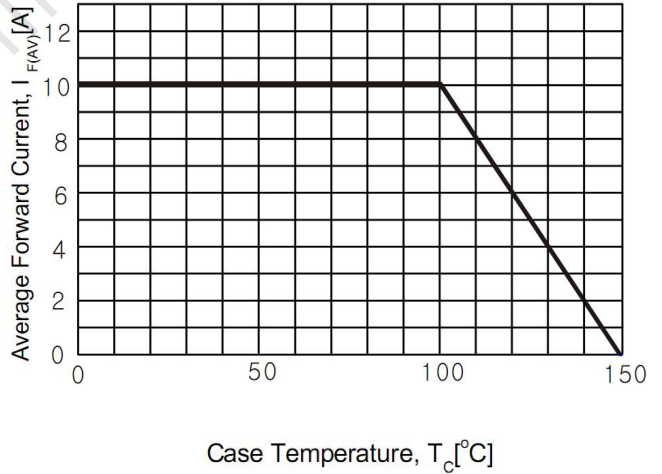
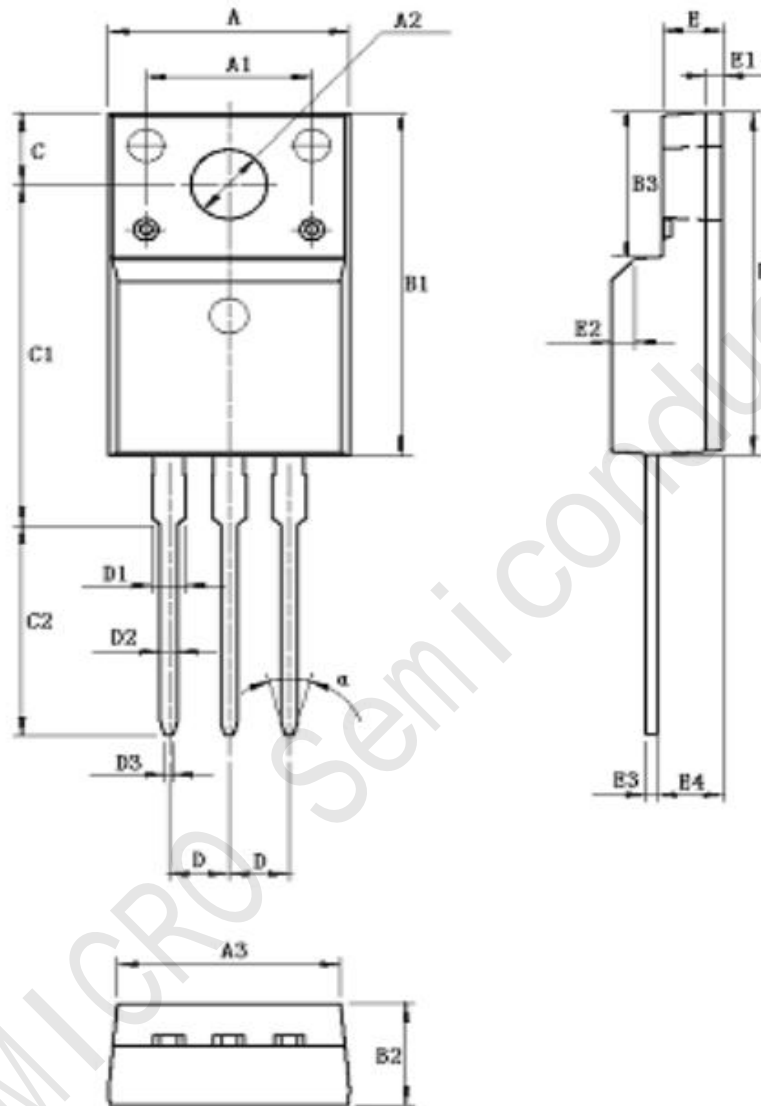

Figure 4. Power Derating



### TO-220F Package Dimensions



UNIT: mm

SYMBOL	min	nom	max	SYMBOL	min	nom	max
A	9.80		10.60	D		2.54	
A1		7.00		D1	1.15		1.55
A2	2.90		3.40	D2	0.60		1.00
A3	9.10		9.90	D3	0.20		0.50
B1	15.40		16.40	E	2.24		2.84
B2	4.35		4.95	E1		0.70	
B3	6.00		7.40	E2		1.0×45°	
C	3.00		3.70	E3	0.35		0.65
C1	15.00		17.00	E4	2.30		3.30
C2	8.80		10.80	α (度)		30°	